

StackLight™ 200 Class 36mm



Edwards 200 Class 36mm StackLight is a versatile signaling device that may contain up to six light modules, or five light modules with one sounder module in a single, integrated stack. The sounder module has been designed so that it is always in the top position.

The lens modules are available as steady-on, LED light sources. The lenses are made from a self-extinguishing polycarbonate material and are scratch and impact resistant.

Features and Specifications

- LED light source
- Steady-on
- dB rating: 72dB @ 1 meter/62dB @ 10ft.
- Interlocking system for quick assembly
- Available in gray or black
- One optional IP54 rated sounder available:
 - Piezoelectric: one single tone
- Additional mounting options available
- NEMA Type 3R rated
- IP65 rated base and light modules
- Operating temperature range: -22F° to 122°F (-30°C to 50°C)



← 1.77" →



Ordering Information

Description	Cat. No.*
Wiring Base and Cover - Gray	236BC

Module Type	Cat. No.*	Operating Voltage ¹	Current	LED Color
Gray LED Steady-on	236LEDSB24AD	24V AC/DC	0.050 A	Blue
	236LEDSA24AD	24V AC/DC	0.045 A	Amber
	236LEDSR24AD	24V AC/DC	0.050 A	Red
	236LEDSG24AD	24V AC/DC	0.040 A	Green
	236LEDSY24AD	24V AC/DC	0.045 A	Yellow
	236LEDSW24AD	24V AC/DC	0.050 A	White
Gray - Piezoelectric Acoustic	236PZO	24V AC/DC	0.010 A	

*NOTE: Add "B" to end of the catalog number for Black unit.

¹AC voltage frequency is 50/60 Hz



StackLight™

200 Class

36mm

Accessories

Description	Cat. No.
Junction Box - Gray	270JBX*
Footring with Extension - Gray	270KIT*
Threaded Extension Pole 100mm - Gray	270TEP*
Threaded Footring - Gray	270THF*
Threaded Wall Mount - Gray	270TWM*
Double Threaded Wall Mount - Gray	270TWM2*
270 Flexible Steel Extension Rod - 370mm	270FLXT
270 Stainless Steel Extension Rod - 100mm	270SSXT100
270 Stainless Steel Extension Rod - 200mm	270SSXT200
270 Stainless Steel Extension Rod - 400mm	270SSXT400

*NOTE: Add "B" to end of the catalog number for Black unit.



Junction Box



Threaded Footring



Footring with Extension



Threaded Extension Pole



100mm

200mm

400mm

370mm

Stainless Steel Extension Rod

Flexible Steel Extension Rod



Threaded Wall Mount



Double Threaded Wall Mount

StackLight™

200 Class

36mm

Weights and Dimensions

Cat. No.	Approx. Net Weight (lb.)	Approx. Shipping Weight (lb.)
236BC	0.12	0.33
236LEDS*24AD	0.04	0.24
236PZO	0.10	0.30
270JBX	0.22	0.09
270KIT	0.13	1.10
270TEP	0.07	0.22
270THF	0.07	0.29
270TWM	0.09	0.59
270TWM2	0.11	0.62
270FLXT	0.57	1.30
270SSXT100	0.31	1.28
270SSXT200	0.40	1.30
270SSXT400	0.62	1.50

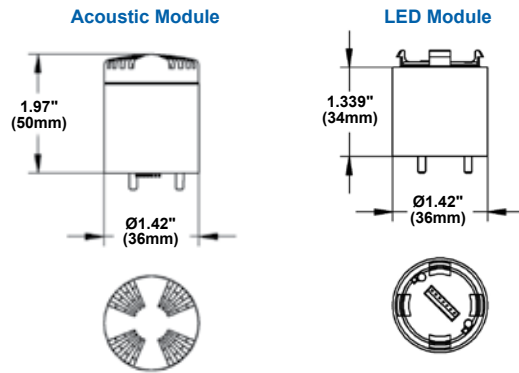

*Letter in this position designates lens color: A - amber, B - blue, G - green, R - red, W - clear or Y - yellow

Base and Cover

